

GIBRALTAR

BUILDING ACCESSORIES DIVISION

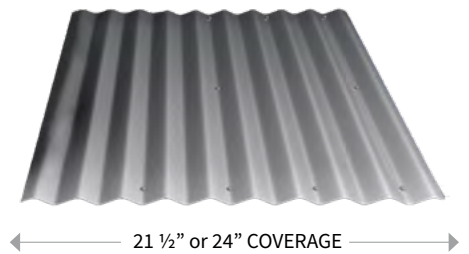

CORRUGATED DETAIL MANUAL



- ✓ Easy to cut with standard tin snips
- ✓ Long service life and fully recyclable
- ✓ Available in 2 1/2" and 1 1/4" sizes
- ✓ 31-Gauge thickness, recommended for roof slopes of 3/12 pitch or greater
- ✓ Provides 21-1/2 in. roof coverage or 24 in. siding coverage
- ✓ Suitable for residential, agricultural, and interior applications
- ✓ Wide variety of colors panels and accessories

FOR OVER 50 YEARS... TRUSTED QUALITY TESTED STRENGTH®

CONTENTS

IMPORTANT INFORMATION	2
INSTALLATION INFORMATION.....	6
TECHNICAL INFORMATION	7
TRIMS AND FLASHINGS ILLUSTRATION.....	8
ROOFING INSTALLATION DETAILS	
Fascia Cover FC-5/FC-7/FC-9.....	10
Eave Drip ED-1	11
Eave Flashing EF-3.....	12
Preformed Valley PV-1/PV-2	13
End Wall Flashing EW-1	14
Side Wall Flashing SW-1.....	15
Transition Flashing TF-1	16
Gambrel Flashing GF-1	17
Gable Rake EF-3.....	18
High Side Eave HS-2	19
Hip Cap RC-2	20
Ridge Cap RC-3	21
Ridge Cap RC-8.....	22
Vented Ridge with Miami-Dade Approved Vented Closure	23
Pipe Boot	24
FASTENER GUIDE	25
SEALANT AND ACCESSORIES	26
HELPFUL FORMULAS	27
FLASHING ANGLE SPECIFIER CHART.....	28

I IMPORTANT INFORMATION

AVAILABLE FINISHES

Bare, unpainted Galvanized steel

A protective layer of pure, molten zinc is applied over a steel core at the steel mill using the Hot-Dipped-Galvanizing process. The layer pure zinc is sacrificial in nature and helps to protect the carbon steel core from corrosion. Galvanized steel is typically shiny when new and weathers, while not always uniformly, to a dull gray. Bare Galvanized steel is not covered by any warranty.

Bare, unpainted aluminum-zinc alloy coated steel with clear acrylic coating

Trademarked as Acrylume by United States Steel (a.k.a. Galvalume when not coated with acrylic) and Zinalume Plus by Steelscape (a.k.a. Zinalume when not coated with acrylic). While Galvanized steel consists of a pure layer of zinc over carbon steel, the aluminum zinc alloy is a coating of 55% aluminum, 43.4% zinc, and 1.6% silicone (thus the term “alloy”) and provides superior corrosion resistance to the carbon steel core, nearly twice that of Galvanized steel! Molten aluminum-zinc alloy is applied over a steel core at the steel mill using a Hot-Dipped process and provides a layer of protection that provides the best of both worlds in corrosion protection: the aluminum provides barrier protection and the zinc provides the sacrificial protection. The clear acrylic coating is then applied to prevent hand and foot marking which can cause aesthetic concerns while additionally providing both increased formability and increased corrosion protection during transit and storage. While the clear acrylic coating provides a level of assurance that the finished appearance of both new and weathered material will be uniform, it is still a mill finish product and if nearly perfect uniformity of the finish is expected, a painted finish should be selected. Aluminum-zinc alloy coated steel with clear acrylic coating is covered by a limited, twenty-five (25) year warranty against rupture, structural failure and perforation. Please refer to the aluminum-zinc alloy coated steel with acrylic coating warranty for specific terms and conditions-- one such exclusion is that metal substrate corrosion as exhibited by surface rusting is not covered by the warranty.

Painted, Polyester coated metal

The Polyester resin paint system is applied to properly cleaned and pre-treated metallic coated steel (Hot-Dipped Galvanized steel or aluminum-zinc alloy coated steel) or aluminum to provide a durable painted finish that is cost effective and offers excellent surface hardness, flexibility and resistance to metal marking. The Polyester resin paint is applied to the metal substrate using a state-of-the-art continuous coil coating line that cleans and pre-treats the metal prior to painting. Steel substrates utilize a 2-coat system consisting of compatible primer and color coat on the exposed surfaces and an additional 2-coat system on the unexposed side of the steel. Aluminum substrates are prepared with similar cleaning and pre-treatments but utilize a fully compatible single coat color system applied directly to exposed surfaces and a single coat clear or tinted system applied directly to unexposed surfaces of the aluminum. Polyester painted metal is covered by a limited, ten (10) year film integrity warranty. Please refer to the Polyester Paint warranty for specific terms and conditions-- one such exclusion is that metal substrate corrosion as exhibited by rusting is not covered by the Polyeseater Paint warranty.

Painted, Siliconized Polyester coated metal

The Silicone Modified Polyester (SMP) resin paint system is applied to properly cleaned and pre-treated metallic coated steel (Hot-Dipped Galvanized steel or aluminum-zinc alloy coated steel) to deliver an excellent balance of exterior gloss, color retention, chalk resistance, formability and overall cost effectiveness in a wide variety of colors. Siliconized Polyester paint is a premium system versus a straight Polyester system as exhibited by superior chalk and fade resistance. The paint system is applied to the metal substrate using a state-of-the-art continuous coil coating line that cleans and pre-treats the metal prior to painting. The metal continues through the continuous coil coating line where a 2-coat paint system consisting of compatible primer and color coat are applied to the exposed surfaces and an additional 2-coat system is applied to the unexposed side of the metal. Siliconized Polyester painted metal is covered by a limited, forty (40) year warranty. Please refer to the Siliconized Polyester Paint warranty for specific terms, conditions and coverages for film integrity, chalk resistance and fade resistance-- one such exclusion is that metal substrate corrosion as exhibited by rusting is not covered by the SMP warranty.

Painted, 70% Fluoropolymer (PVDF) coated metal

70% Fluoropolymer (PVDF) resins, often referred to by their trademarked systems Kynar 500 (by Arkema) and Hylar 5000 (by Solvay), have been the success behind some of the highest performing paint systems available on metal panels used throughout the world. Fluoropolymers deliver outstanding aesthetics and durability for an array of high-end architectural applications including metal roof and wall panels and have set the standard for excellence in architectural finishes with their proven resistance to color fading, acid rain, ultraviolet rays and chipping and peeling. The paint system is applied to the metal substrate using a state-of-the-art continuous coil coating line that cleans and pre-treats the metal prior to painting. The metal continues through the continuous coil coating line where a 2-coat paint system consisting of compatible primer and color coat are applied to the exposed surfaces and an additional 2-coat system is applied to the unexposed side of the metal. 70% Fluoropolymer (PVDF) painted metal is covered by a limited, forty-five (45) year warranty. Please refer to the PVDF warranty for specific terms, conditions and coverages for film integrity, chalk resistance and fade resistance-- one such exclusion is that metal substrate corrosion as exhibited by rusting is not covered by the PVDF Paint warranty.

COLORS

For panel color selection, please refer to the Gibraltar Metal Roofing Color Chart.

JOB ESTIMATING AND TAKEOFFS

Gibraltar offers this valuable service at no charge. In order to complete estimation requests, it is absolutely necessary that Gibraltar be furnished with detailed, accurate information and drawings regarding the project prior to assistance.

Gibraltar can assist customers in determining the amount and length of material required for the project, but it is the customer's responsibility to review and field verify the material required to complete the project. Gibraltar will not be held accountable for incorrect lengths and quantities. Prior to ordering and installing materials, all dimensions should be verified by field measurements.

LOCAL CODE COMPLIANCE

Building codes for metal roofing applications vary by county and project. For information regarding pertinent building code requirements and ordinances, contact your local building code organization.

Gibraltar acts only as the seller of roofing materials and has no control of the application of materials or the conditions under which they are applied. A registered engineer or architect of record for the project assumes the responsibility of detailing the applications.

WARRANTIES

Bare, unpainted Galvanized steel

No warranty is available.

Bare, unpainted aluminum-zinc alloy coated steel with clear acrylic coating

Aluminum-zinc alloy coated steel with clear acrylic coating is covered by a limited, twenty-five (25) year warranty against rupture, structural failure and perforation under normal weathering conditions. Please refer to the aluminum-zinc alloy coated steel with acrylic coating warranty for specific terms and conditions-- one such exclusion is that metal substrate corrosion as exhibited by surface rusting is not covered by the warranty. Metal installations in aggressive or severe environments such as those ½ mile or less from a coastline are not warranted. Metal installations greater than ½ mile but less than 1-mile from a marine environment are warranted under the same terms and conditions except that the duration of the warranty is reduced to five (5) years.

IMPORTANT INFORMATION

Painted, Polyester coated metal

Polyester painted metal is covered by a limited, ten (10) year film integrity warranty. Please refer to the Polyester Paint warranty for specific terms and conditions-- one such exclusion is that metal substrate corrosion as exhibited by rusting is not covered by the Polyester Paint warranty. Film integrity can be defined as paint that does not peel, check, chip or crack under normal weathering conditions. Metal installations in aggressive or severe environments such as those 1000 feet or less from a coastline are not warranted. Metal installations greater than 1000 feet but less than 1-mile from a marine environment require an annual maintenance program of the building in the form of a third party verified annual "sweet water" (fresh tap water) rinse in accordance with AAMA 610.1-1979 (copy available upon request).

Painted, Siliconized Polyester coated metal

Siliconized Polyester painted metal under normal weathering conditions is covered by a limited, forty (40) year warranty. Please refer to the SMP Paint warranty for specific terms, conditions and coverages for film integrity, chalk resistance and fade resistance-- one such exclusion is that metal substrate corrosion as exhibited by rusting is not covered by the SMP Paint warranty. Film integrity can be defined as paint that does not peel, check, chip or crack. Chalk refers to the development of loose, removable powder that comes from the coating itself upon breakdown of its resin or binder. Fade ratings are based on a number of NBS delta E unit differences in change of color from the original color. Metal installations in aggressive or severe environments such as those 1000 feet or less from a coastline are not warranted. Metal installations greater than 1000 feet but less than 1-mile from a marine environment require an annual maintenance program of the building in the form of a third party verified annual "sweet water" (fresh tap water) rinse in accordance with AAMA 610.1-1979 (copy available upon request).

Painted, 70% Fluoropolymer (PVDF) coated metal

70% Fluoropolymer (PVDF) painted metal under normal weathering conditions is covered by a limited, forty-five (45) year warranty. Please refer to the PVDF Paint warranty for specific terms, conditions and coverages for film integrity, chalk resistance and fade resistance-- one such exclusion is that metal substrate corrosion as exhibited by rusting is not covered by the PVDF Paint warranty. Film integrity can be defined as paint that does not peel, check, chip or crack. Chalk refers to the development of loose, removable powder that comes from the coating itself upon breakdown of its resin or binder. Fade ratings are based on a number of NBS delta E unit differences in change of color from the original color. Metal installations in aggressive or severe environments such as those 1000 feet or less from a coastline are not warranted. Metal installations greater than 1000 feet but less than 1-mile from a marine environment require an annual maintenance program of the building in the form of a third party verified annual "sweet water" (fresh tap water) rinse in accordance with AAMA 610.1-1979 (copy available upon request).

DELIVERY, HANDLING AND STORAGE

Proper care in storing and handling metal panels is essential in providing you with years of service. Panels should be installed immediately to prevent storage oxidation or paint peel. Any panels not immediately installed must be kept dry and stored in an indoor area. Extreme caution should be taken in order to prevent moisture penetration of the stack(s) by rain, snowfall or condensation. Condensation is moisture that accumulates naturally from the change in temperature of the material nested in a stack where adequate ventilation has been restricted.

Store the panels off the ground, on wooden blocks with one end slightly elevated. Cut banding to allow the stack to expand and allow a small amount of ventilation. Cover the stack with loose canvas tarp or waterproof paper. Covering should be placed over the stack but never tightly secured to the ground to allow air flow. Do not cover metal with plastic as this can create condensation.

SAFETY PRECAUTIONS

It is the responsibility of the buyer to ensure the safe installation of these product systems. Metal panels have sharp edges, therefore protective clothing and gloves should be utilized. To prevent eye injury, safety glasses must be worn when drilling or cutting steel panels. Steel panels can become slippery when wet. Use extreme care when walking on any roofing panel. Proper underlayment is necessary to prevent fall-through. Plywood is recommended on all non-structural panel applications. Do not work on steel panels when wet or when weather conditions are not suitable for safe installation.

Gibraltar recommends all installers comply with the Florida Fall Protection Act, all OSHA (Occupational Safety & Health Administration) requirements (#3146, dated 1995), and any other applicable safety rules or laws.

CANCELLATIONS

Gibraltar will honor cancellation prior to manufacturing. Any order which has already been manufactured is the property of the purchaser.

CLAIMS

All claims of shortage, damage, etc. must be made within 48 hours of the date of receipt. Claims must be accompanied by a copy of the bill of lading verified by the shipper which must indicate shortages or damages as received. Gibraltar can not honor shortage or damage claims on freight carriers unless the carrier's paperwork is duly noted.

DISCLAIMER

The information contained in this product manual is subject to change without notice. Gibraltar reserves the right to discontinue or modify products and installation methods at any time without notice and incurring no obligation. Contact Gibraltar to obtain the latest information.

Throughout this product manual each panel series is specified per Gibraltar recommended use and application of these products. The use of these products should not vary from these recommendations or should not be applied using another manufacturer's specifications or guidelines. If you have any questions about any of the products and their appropriate applications, please call Gibraltar.

NOTICE: The application details are for illustration purposes only. These details may not be suitable for all building designs or conditions. Projects should be engineered to confirm to building codes, regulations, and industry practices which are applicable. Consult Gibraltar for any additional information not outlined in this manual.

INSTALLATION INFORMATION

PANEL

There are three critical measurements involving roof panels: the length required at the eave, the peak end and the amount of panel lap (if required). In each case a certain measurement is required. Check each measurement to ensure panel placement gives you the distance required at the eave, peak and endlap condition (if required). In most cases any variance can be taken out at the eave and peak.

ACCESSORIES

This publication details the standard line of trims and accessories for Corrugated roofing applications. Additional trims, including custom accessories, are available upon request.

SUBSTRATE

In residential applications, Gibraltar recommends the use of minimum 15/32" plywood or 7/16" OSB decking. Please note that some Authorities Having Jurisdiction (AHJ's) may require thicker plywood and may not allow the use of OSB decking. It is the Contractor's responsibility to ensure proper decking to meet local code requirements. In addition, good roofing practice requires use of a code approved underlayment between the top of the decking and the underside of the metal roof panel. Underlayment, synthetic underlayments and high-temperature peel & stick underlayments must be installed in accordance with manufacturer's installation instructions and local building code requirements to control condensation and minor water intrusion through metal joints and terminations. High-temperature peel & stick underlayments must be used at all eaves and valleys and around all penetrations of the metal roof and must be properly shingle-lapped (onto itself and onto other underlayments) in the direction of flow in the event of water intrusion through metal joints and terminations. When multiple underlayments are present, the Contractor must ensure compatibility of materials in direct contact with one another.

NOTE: Gibraltar does not recommend the use of square headed cap nails. If tin tabs are used to secure the underlayment to the decking material, Gibraltar recommends a separation sheet of 15# felt or rosin paper be used over the underlayment, applied in the same direction as the panels. If the building parameters differ from those stated in the manufacturer's recommended fastening schedule, specific fastening calculations must be computed by the engineer of record.

METAL RE-ROOFING OVER SHINGLES

Gibraltar's metal roofing panels may be installed over existing asphalt shingles, provided the roof decking integrity has been confirmed to be free of any moisture decay that would prevent un-levelness or reduce fastener pull out capacity.

NOTE: Ordinances regarding roofing applications over existing shingles vary by county and state. Check your local building code or Authority Having Jurisdiction (AHJ) for more information. The panels may be applied directly over one layer of existing shingles, provided an underlayment is installed on top to the shingles. Good roofing practice requires a minimum underlayment,

synthetic underlayment or high-temperature peel & stick underlayment installed on top of the shingles and under the metal roofing system and be installed in accordance with manufacturer's installation instructions and local building code requirements. The metal roofing system can also be separated from the underlayment by optional 1" x 3" battens as furring, spaced a maximum of 24" on center and structurally fastened to the deck and/or trusses to meet local wind uplift requirements. The metal roof panels are then fastened to the 1" x 3" battens in accordance with the recommended fastening schedules and application details contained herein.

CAUTION: Direct contact between pressure treated lumber and metal roofing must be avoided to prevent corrosion. When pressure treated lumber must be used with metal, it must be separated with a peel & stick membrane to prevent the metal from coming in direct contact with the pressure treated wood.

METAL ROOFING FIRE RESISTANCE RATINGS

Gibraltar' metal roofing panels have been analyzed for fire resistance ratings according to test criteria set forth by Underwriters Laboratories "Standard Fire Tests of Building Construction and Materials" (ANSI/UL 263), and ASTM E119 and NFPA 251.

The fire resistance rating is for the total assembly and not just the external metal roofing panels. In general, the test criteria is to evaluate the assemblies ability to continue to support the imposed loads and to resist the passage of flame, high temperature, or hot gasses which will ignite combustible sub-assembly, framing, or decking materials from an exterior source. For detail information on specific assembly ratings see the UL Fire Resistance Directory.

Attaining a class "A" or "B" fire rating requires the installation of one of the following - a minimum 1/4" thick Georgia Pacific "Dens Deck"; a minimum 4mm thick Partek Insulation's, Inc. "Roctex"; a minimum 52 1/2# Elks "Versa Shield"; a minimum 5/8" water resistant type X gypsum sheathing with treated core and facer; or any other product with a current product approval - over the combustible deck prior to installing the metal roofing panels.

TRIMMING AND CUTTING STEEL PANELS

Whether cutting with the profile (length-wise) or across the panel (width wise), it is best to use an electric nibbler, shears or hand tin-snips. It is very important to cut panels one at a time with the finish side of the panel facing down on wood blocks. Care should be taken to ensure that the hot metal particles and filings from cutting and securing the panel do not become embedded in the panel.

CAUTION: Filings from screw and panel cuttings must be cleaned off the panel after screws have been applied through the panel to avoid rust marks or "bleeding" on the panels. Failure to comply with the above procedures relieves Gibraltar, and its parent company, Gibraltar Industries, of responsibility for any resulting damage to, or deterioration of the finish and voids any paint or finish warranty.

TECHNICAL INFORMATION

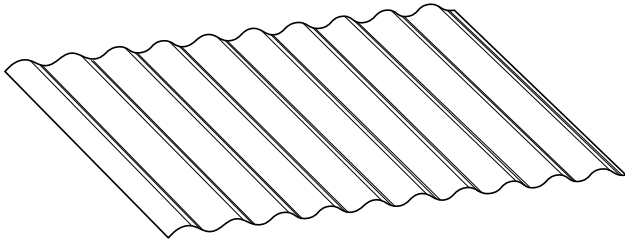

PROFILE DETAIL - 2 1/2" CORRUGATED

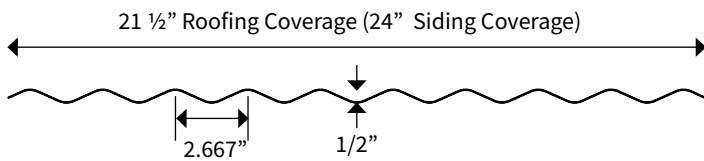

PROFILE DETAIL - 1 1/4" CORRUGATED

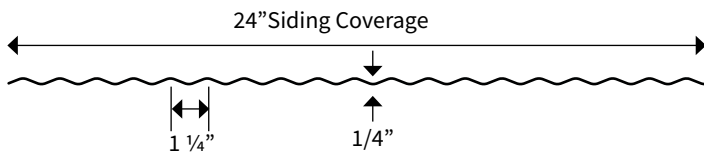

TESTING DATA AND SPECIFICATIONS

- Salt Spray testing of coating 2000 hours per ASTM G23/G155
- Accelerated Testing of coating 1000 hours per ASTM B117
- Fire Testing per ASTM E108 or UL790
- Structural Capacity Test per TAS 125

CODE APPROVALS*

- UL Class A Fire Resistance # R20735
- UL 2218 Hail Impact Class 4 # R20735
- Florida Building Code Approval # FL-11175

*Code Approval numbers may have changed since publication. For the most recent code approval numbers, contact our Engineering team at our Jacksonville, FL or San Antonio TX Plants with any questions.

SIDLAP DETAIL 21-1/2" COVERAGE - ROOFING

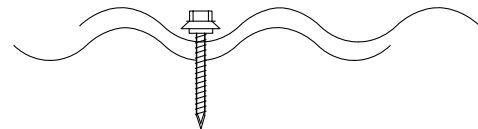

SIDLAP DETAIL - 24" COVERAGE - SIDING

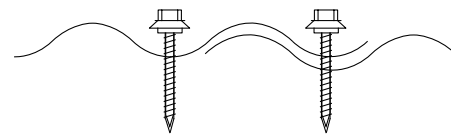

CORRUGATED RECOMMENDED FASTENING SCHEDULE FOR ROOFING

Maximum Tested Design Pressures For 26 Gauge Minimum ¹

Design Pressure-CDX Plywood Thickness	Field Zone 1	Perimeter and Corners Zones 2 and 3
Maximum Design Pressure-Min. 15/32"	-86 psf	-116 psf
Maximum Fastener Spacing	16" on center	12" on center

¹ Interpolation is allowed between Field and Perimeter & Corner test pressure values.

ROOF ZONES

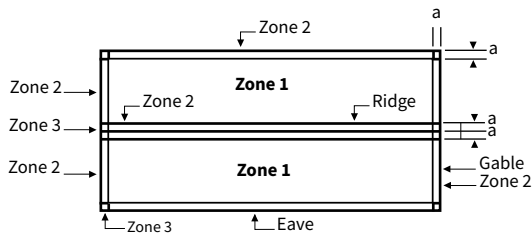

Note: Dimension (a) is defined as 10% of the minimum width of the building or 40% of the mean height of the roof, whichever is smaller, however, (a) cannot be less than either 4% of the minimum width of the building or 3 feet.

FASTENING SCHEDULE

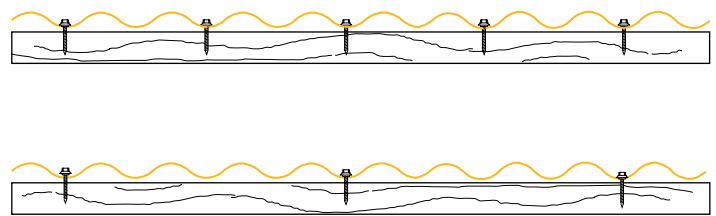

Zone 1

TRIMS AND FLASHINGS

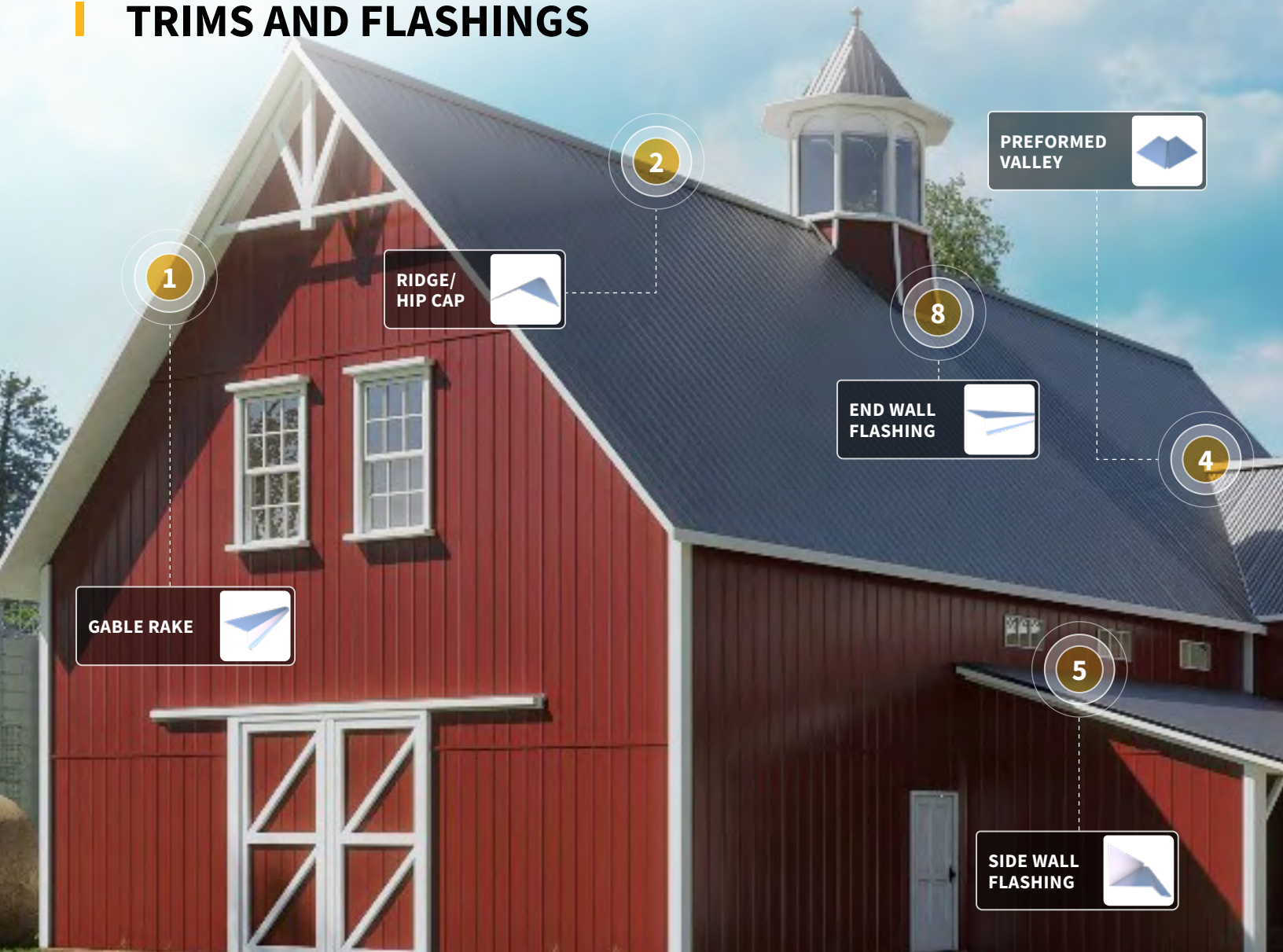

1. GABLE RAKE

EF-3

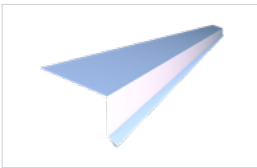

2. RIDGE/HIP CAP

RC-2 OR RC-8



3. RIDGE CAP

RC-3

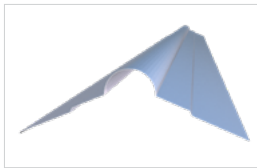

4. PREFORMED VALLEY

PV-1 OR PV-2



5. SIDE WALL FLASHING

SW-1

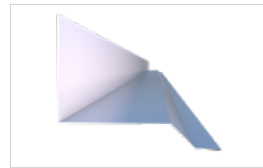

6. EAVE DRIP/EAVE FLASHING

ED-1/EF-3



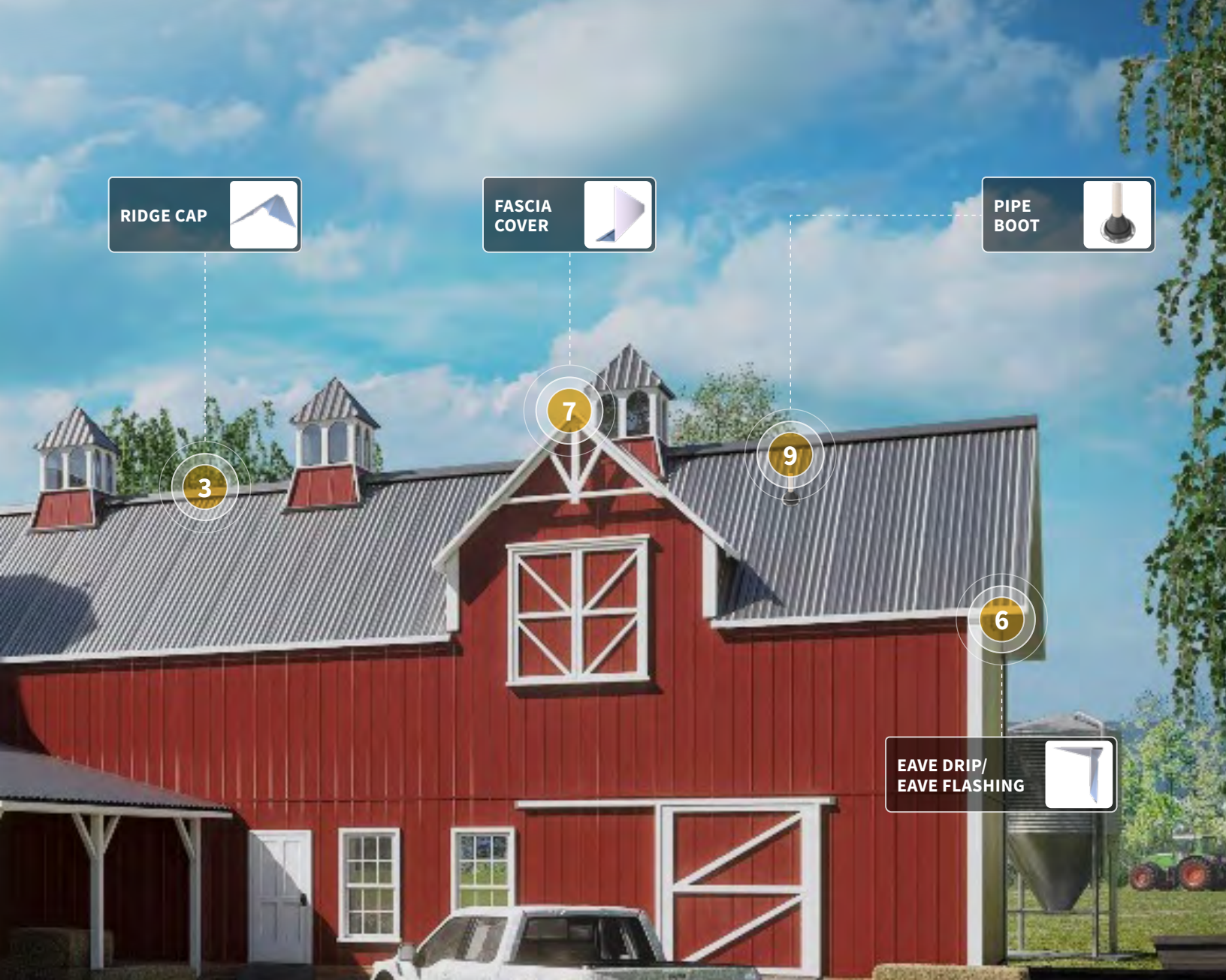

RIDGE CAP 

FASCIA COVER 

PIPE BOOT 

**EAVE DRIP/
EAVE FLASHING** 

7. FASCIA COVER

FC-5/FC-7/FC-9

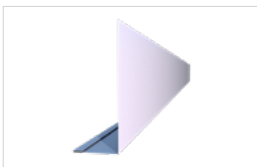

9. PIPE BOOT



11. TRANSITION FLASHING

TF-1 (not pictured above)

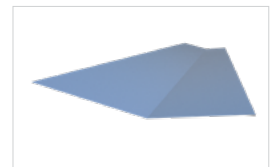

8. END WALL FLASHING

ED-1/EF-3

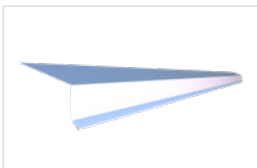

10. GAMBREL FLASHING

GF-1 (not pictured above)



**See Page 25 for accessories used when installing these trims and flashings.*

**Additional and custom trims are available. Please call Technical support for more information.*

FASCIA COVER FC-5/FC-7/FC-9

(10' LENGTHS)

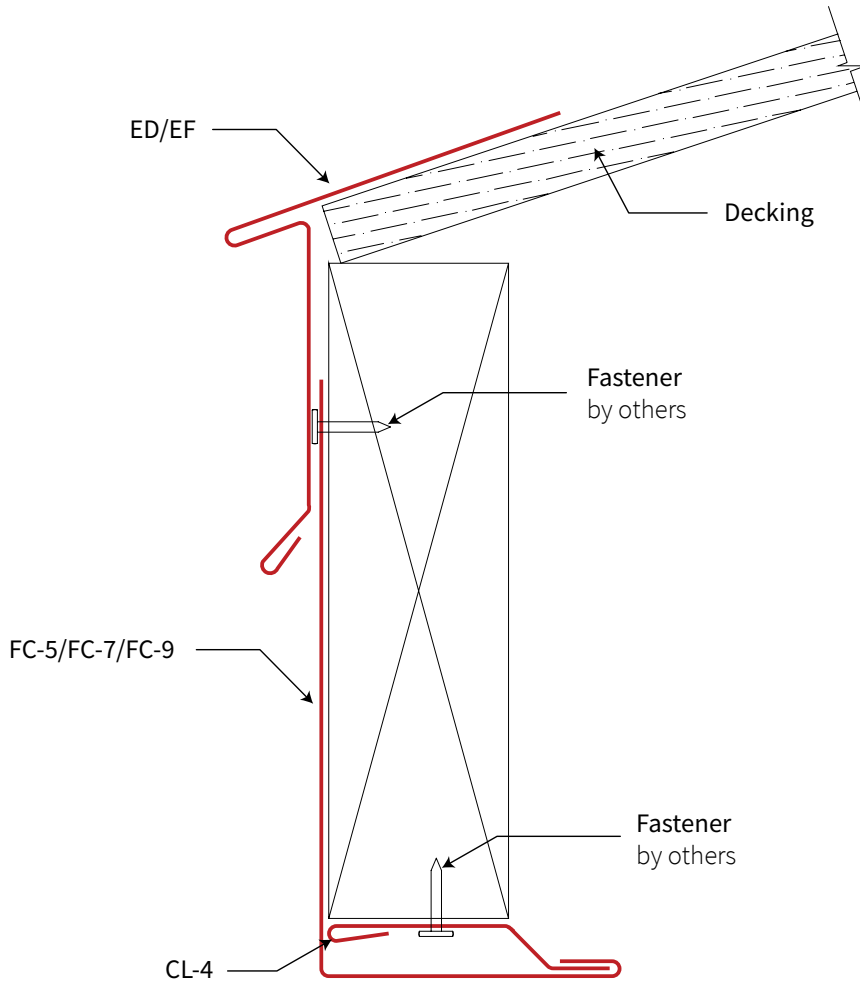

Item	Fascia Size	"A"
FC-5	2" x 6"	5"
FC-7	2" x 8"	7"
FC-9	2" x 10"	9"

COMPONENT DETAILS

FC-5

FC-7

FC-9

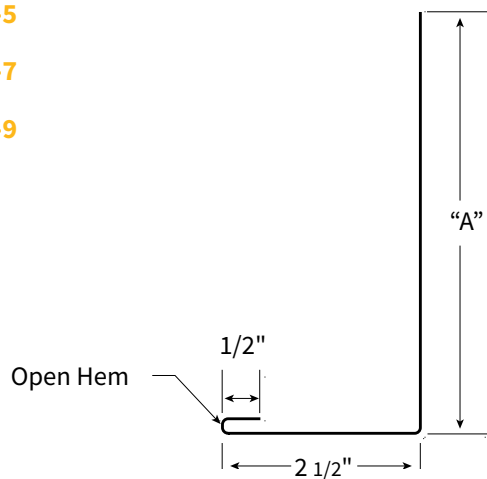

CL-4

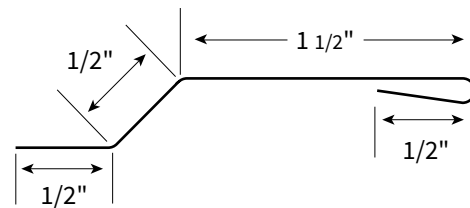

EAVE DRIP ED-1

(10' LENGTHS)

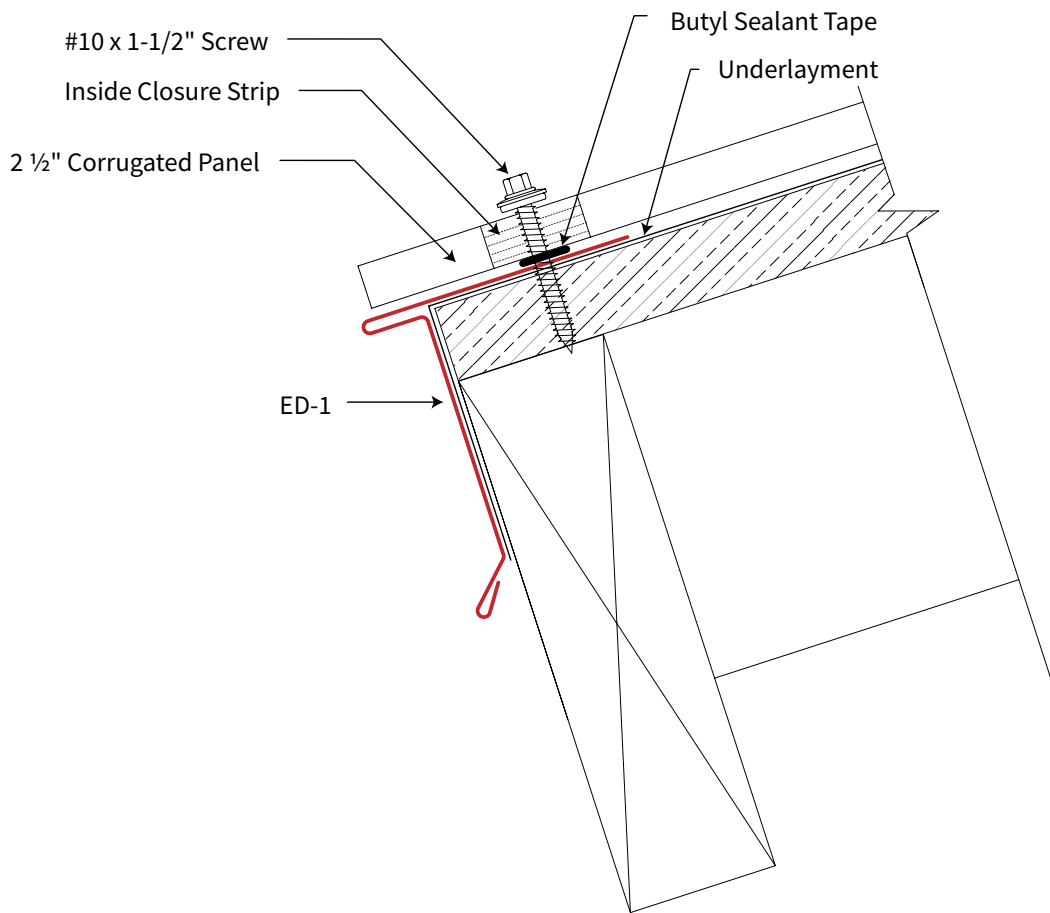

COMPONENT DETAILS

ED-1*

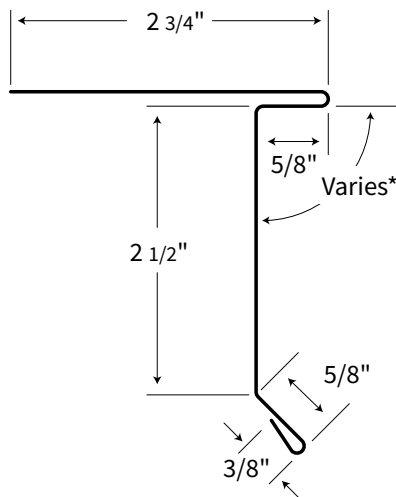

* See page 29 for angle specification

EAVE FLASHING EF-3

(10' LENGTHS)

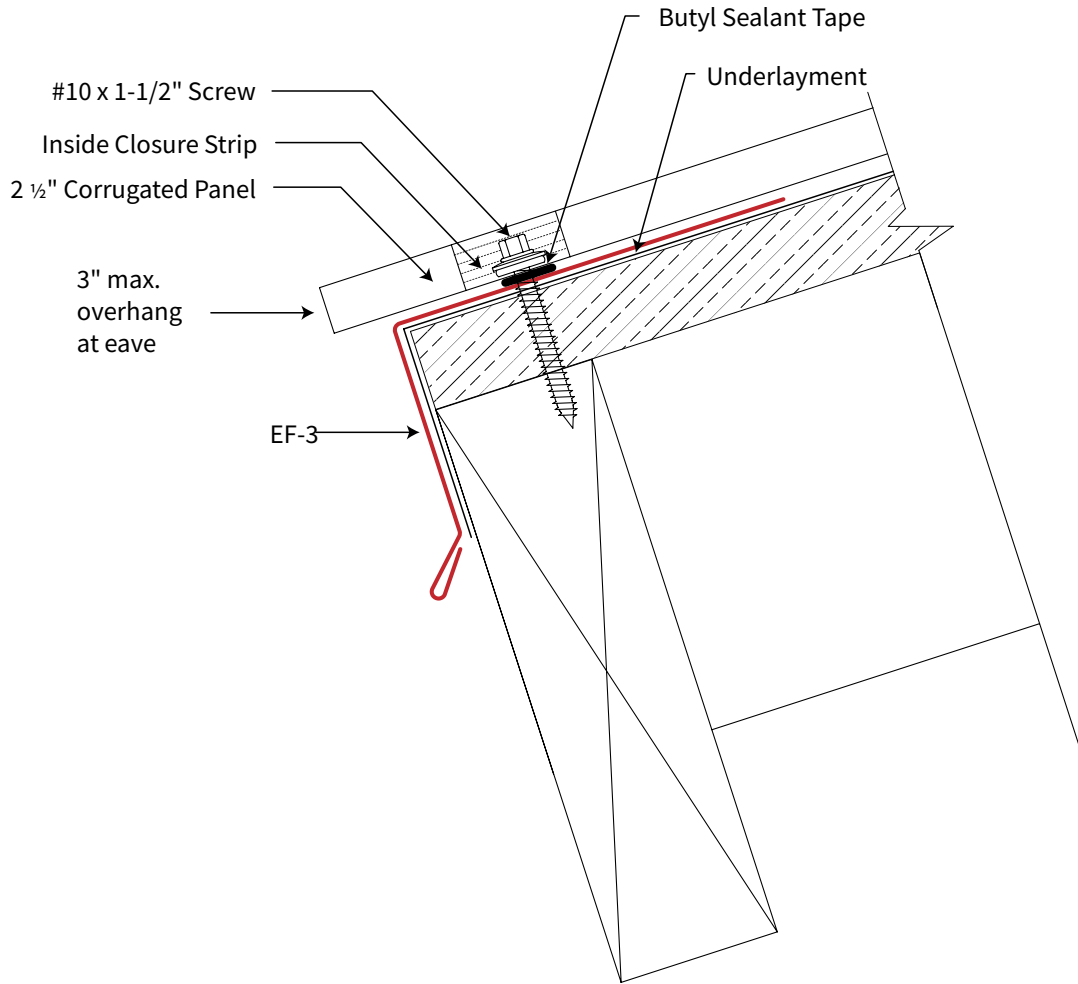

COMPONENT DETAILS

EF-3*

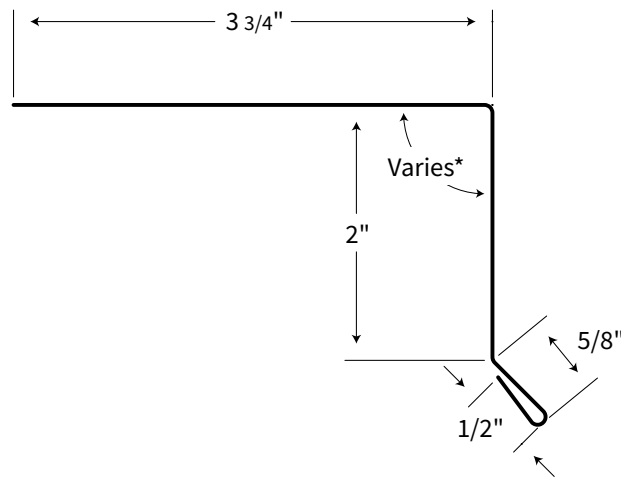

* See page 29 for angle specification

PREFORMED VALLEY PV-1/PV-2

(10' LENGTHS)

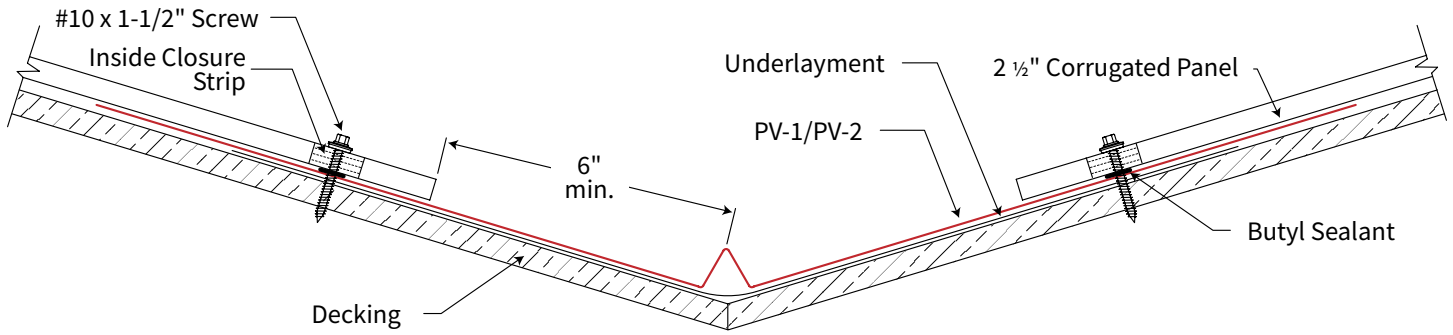

COMPONENT DETAILS

PV-1 - Unhemmed*

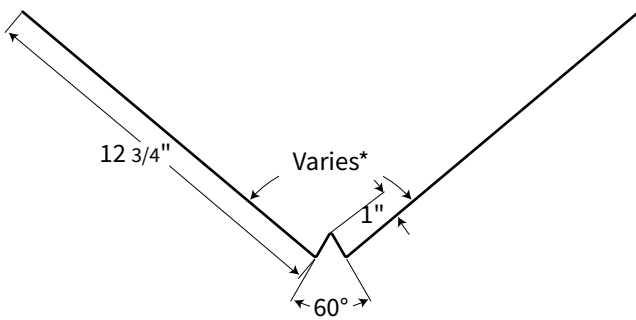

PV-2 - Hemmed*

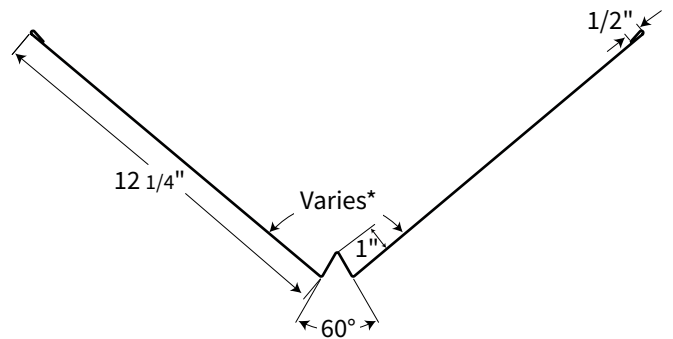

* See page 29 for angle specification

END WALL FLASHING EW-1

(10' LENGTHS)

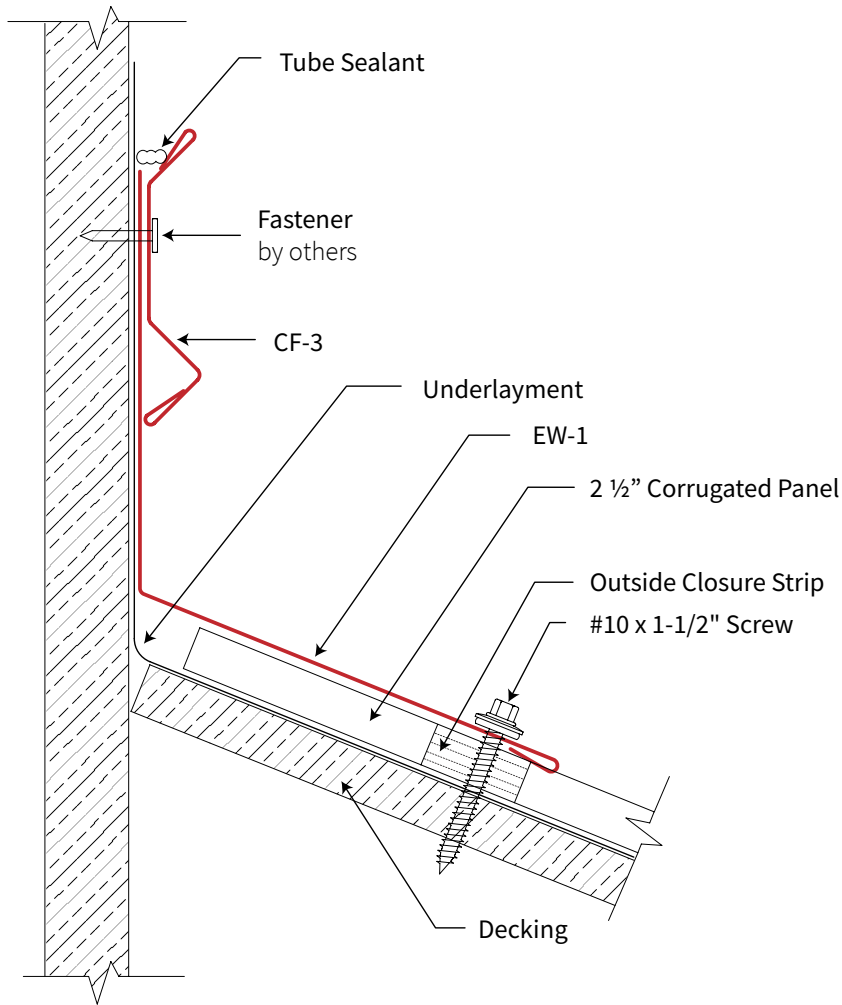

Surface mounting requires use of Counter Flashing (CF-3)

COMPONENT DETAILS

EW-1*

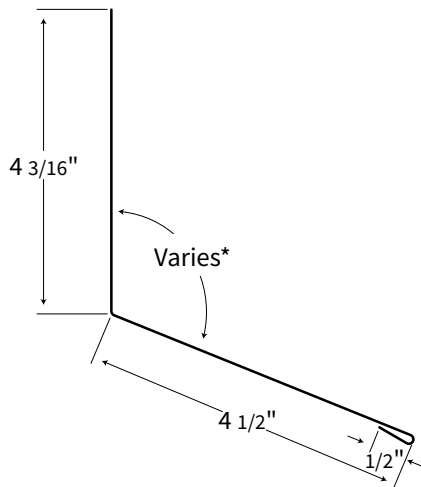

CF-3

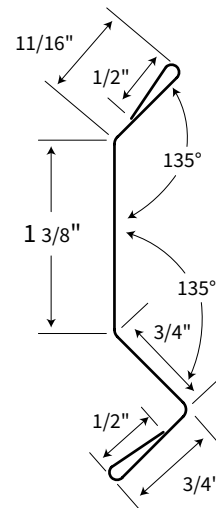

* See page 29 for angle specification

SIDE WALL FLASHING SW-1

(10' LENGTHS)

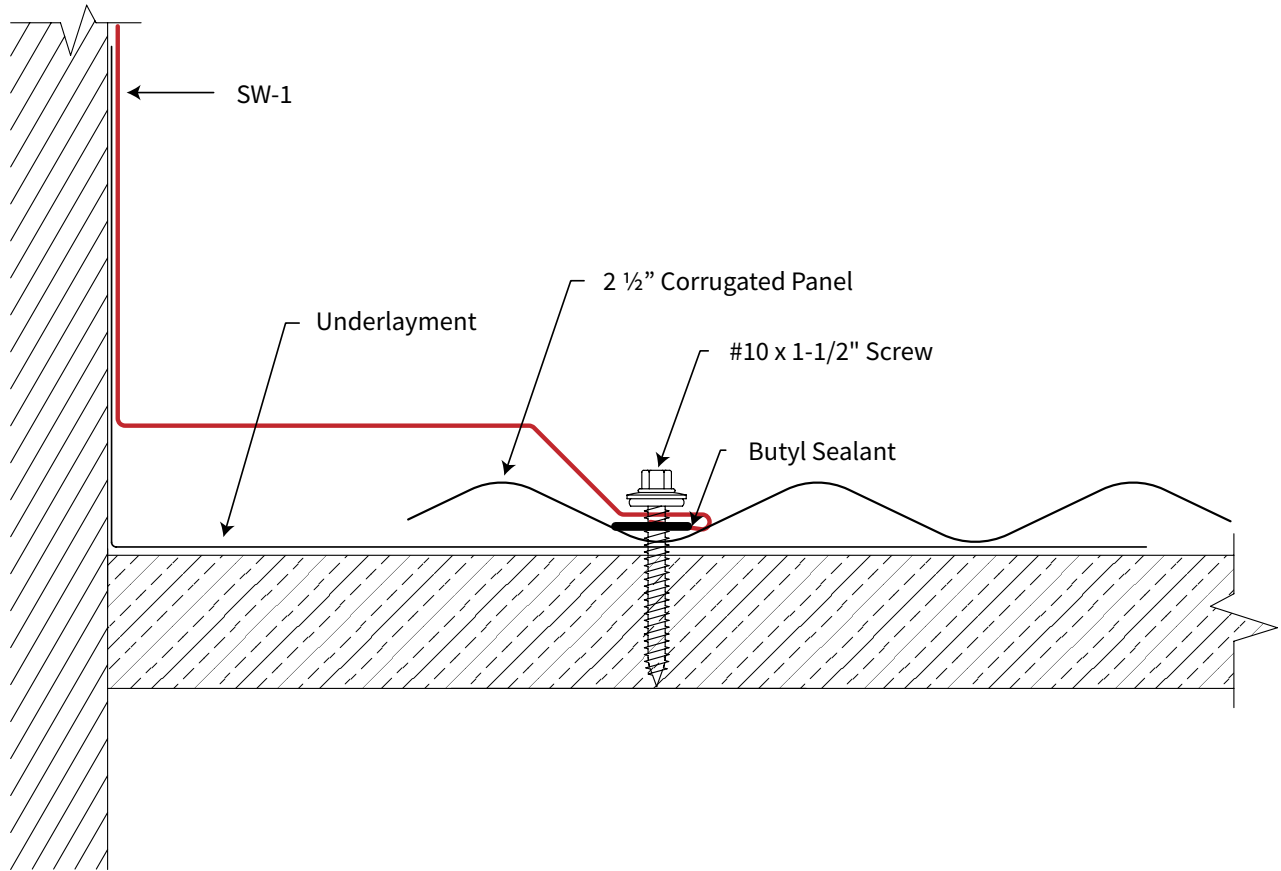

Surface mounting requires use of Counter Flashing (CF-3)

COMPONENT DETAILS

SW-1

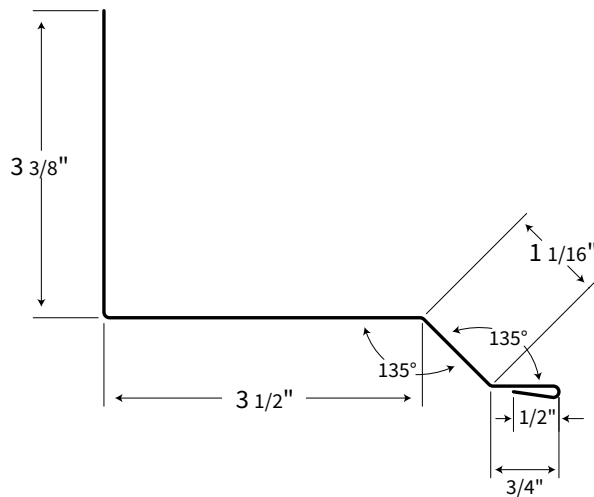

TRANSITION FLASHING TF-1

(10' LENGTHS)

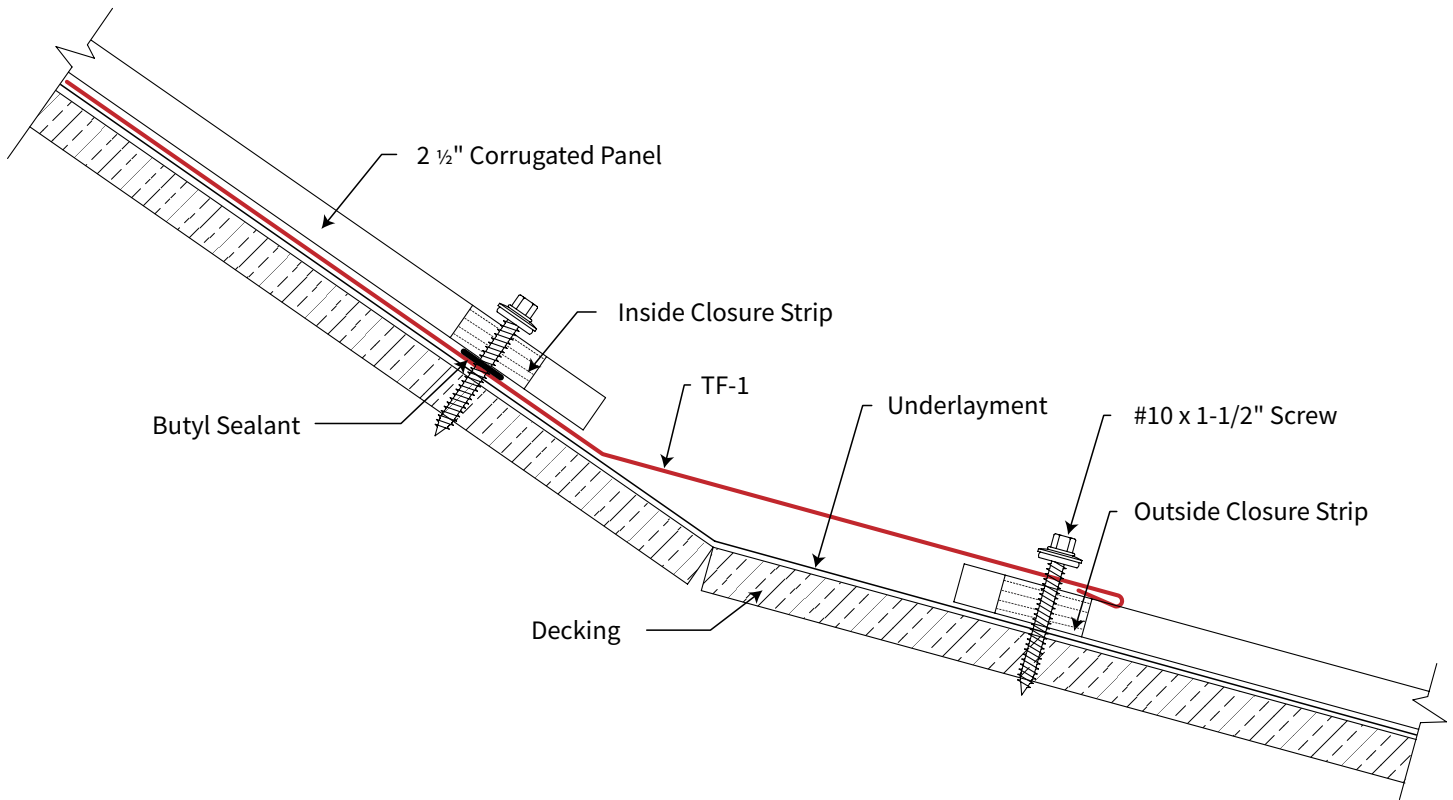

COMPONENT DETAILS

TF-1*

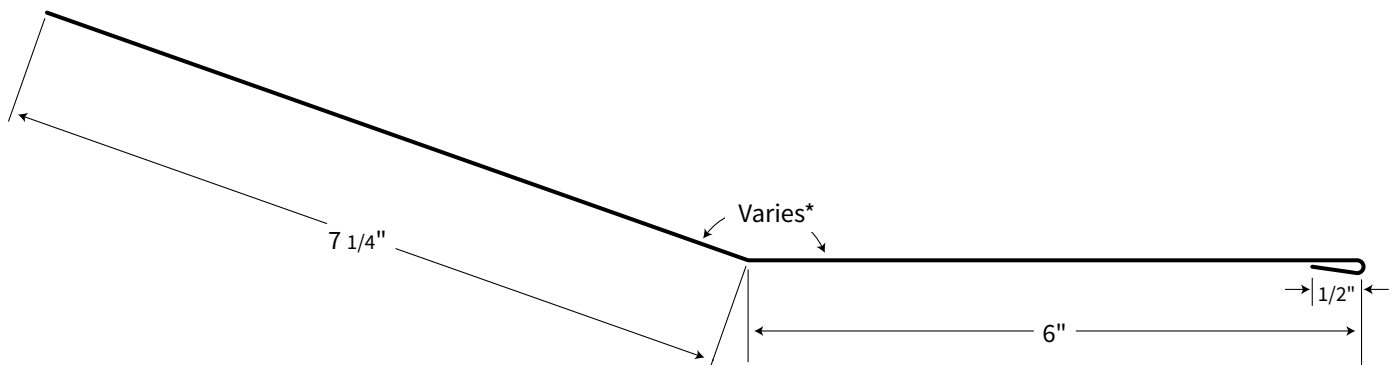

* See page 29 for angle specification

GAMBREL FLASHING GF-1

(10' LENGTHS)

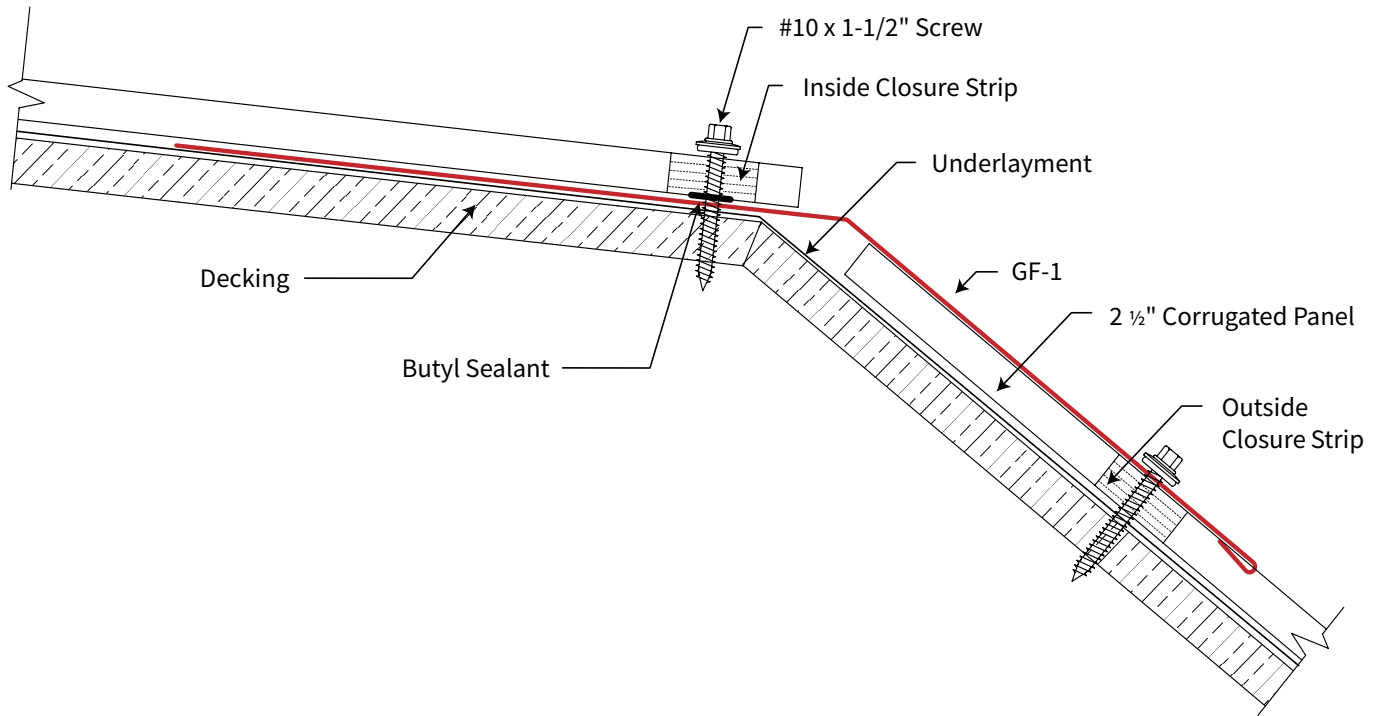

COMPONENT DETAILS

GF-1*

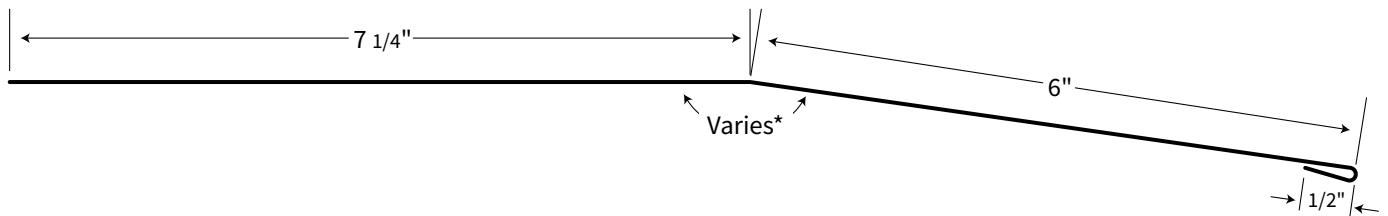

* See page 29 for angle specification

GABLE FLASHING EF-3

(10' LENGTHS)

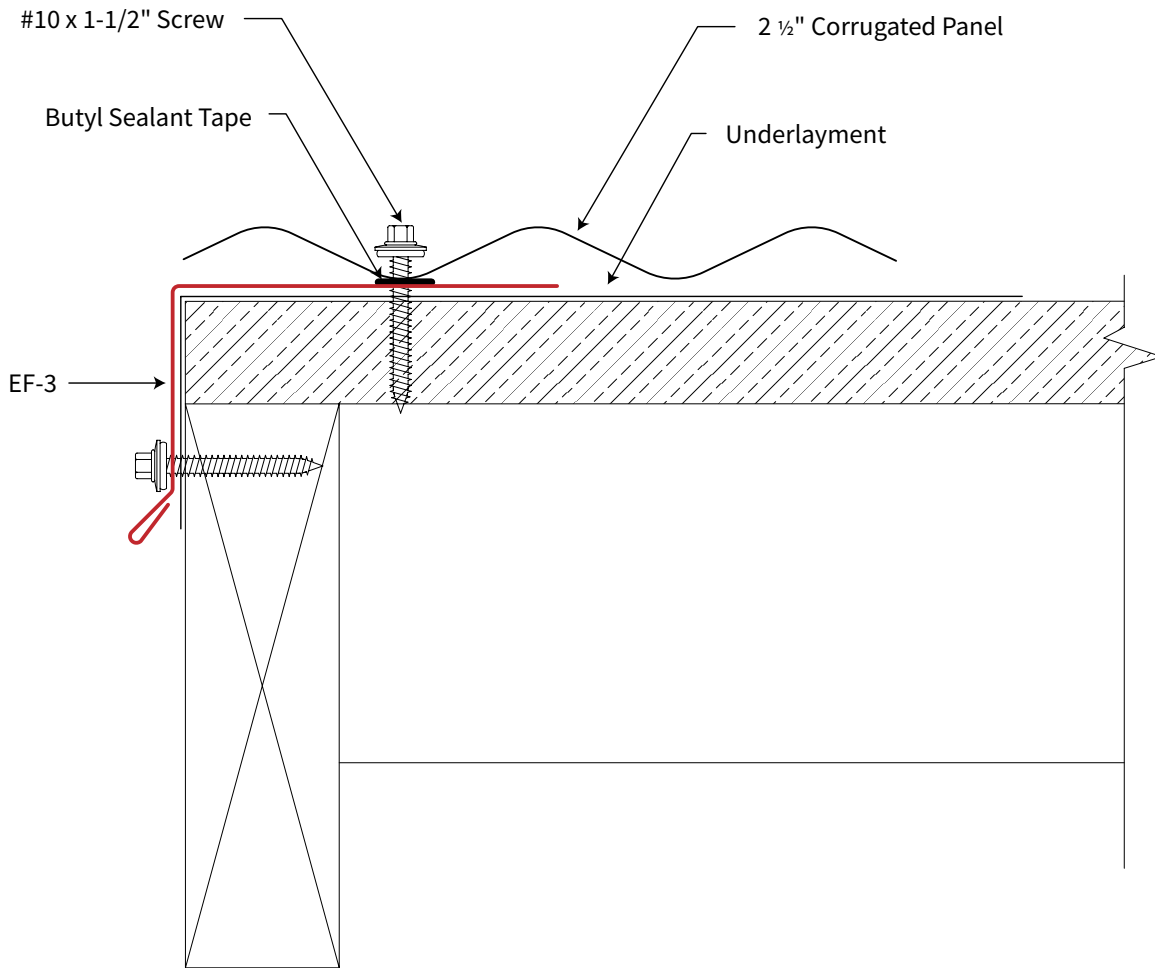

COMPONENT DETAILS

EF-3*

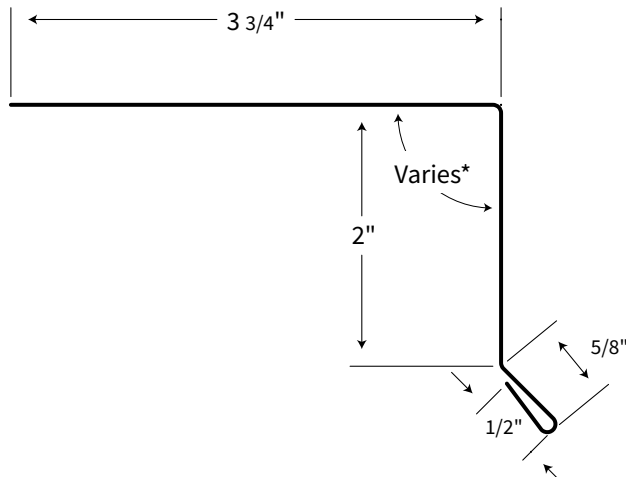

* See page 29 for angle specification

HIGH SIDE EAVE HS-2

(10' LENGTHS)

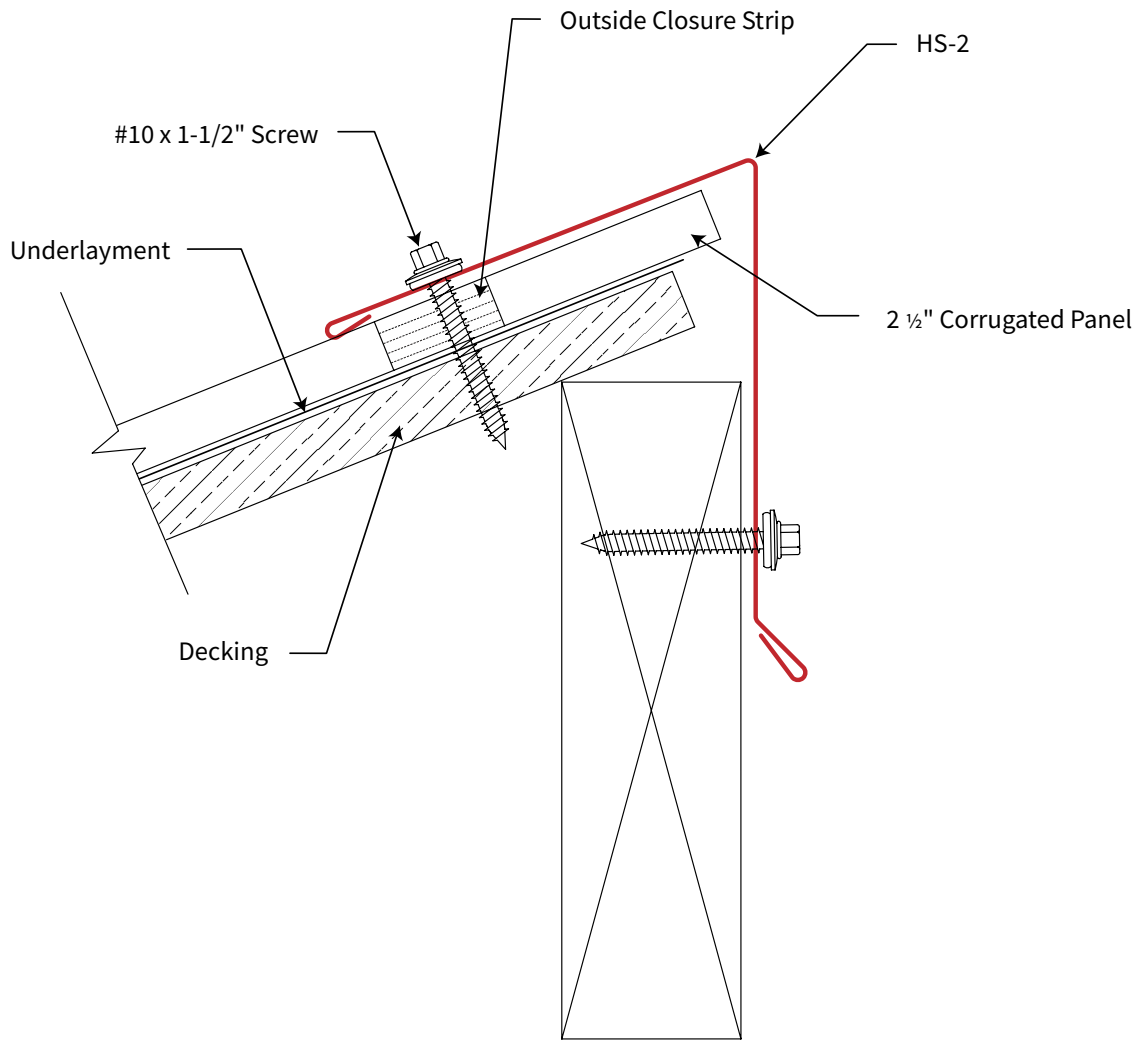

COMPONENT DETAILS

HS-2*

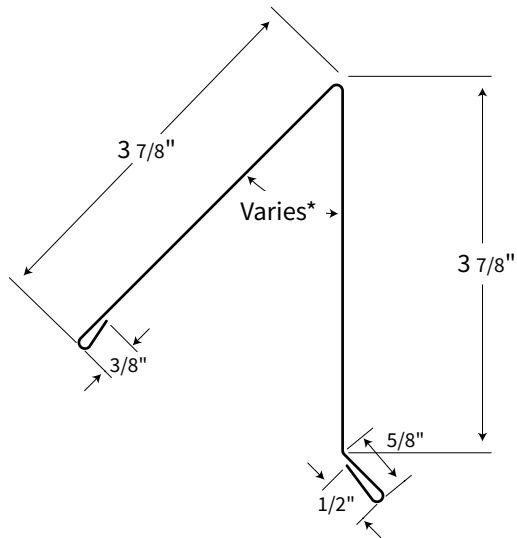

* See page 29 for angle specification

HIP CAP RC-2

(10' LENGTHS)

Option 1

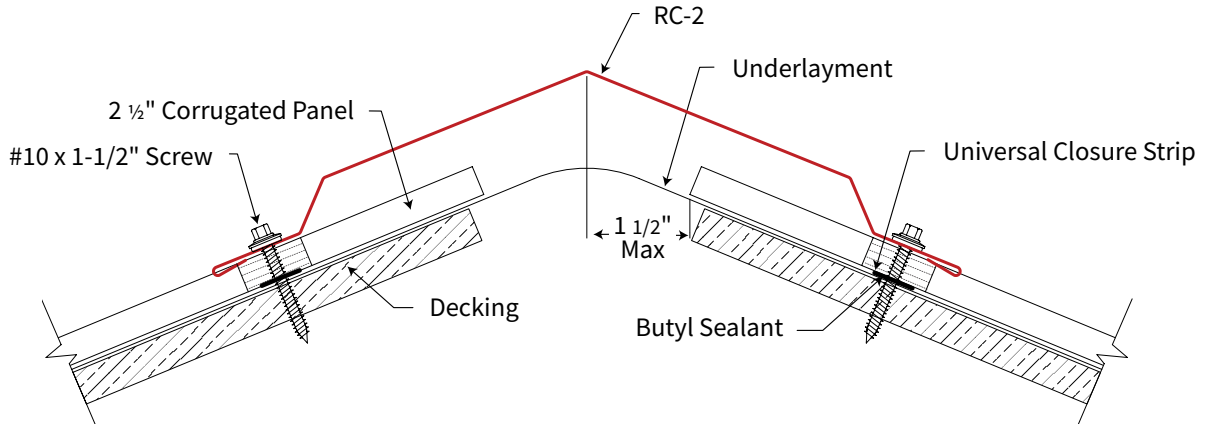

Option 2

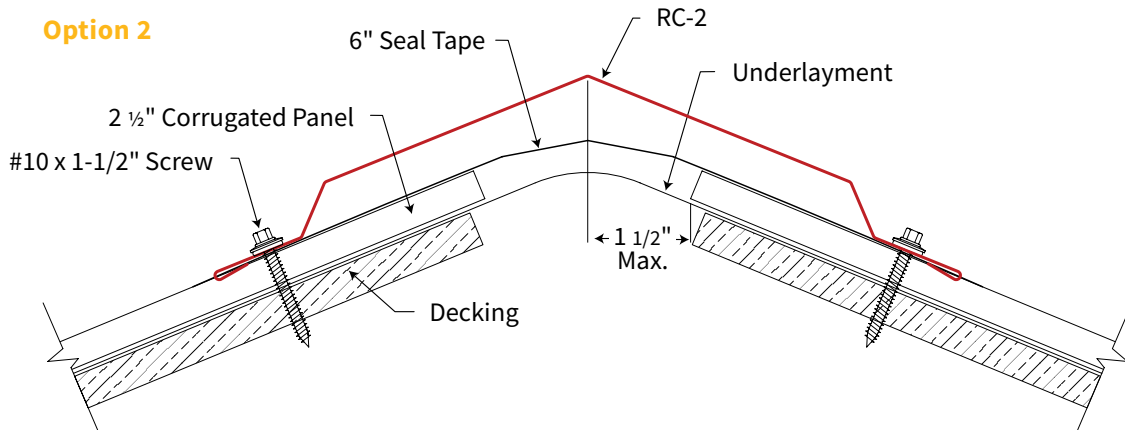

COMPONENT DETAILS

RC-2*

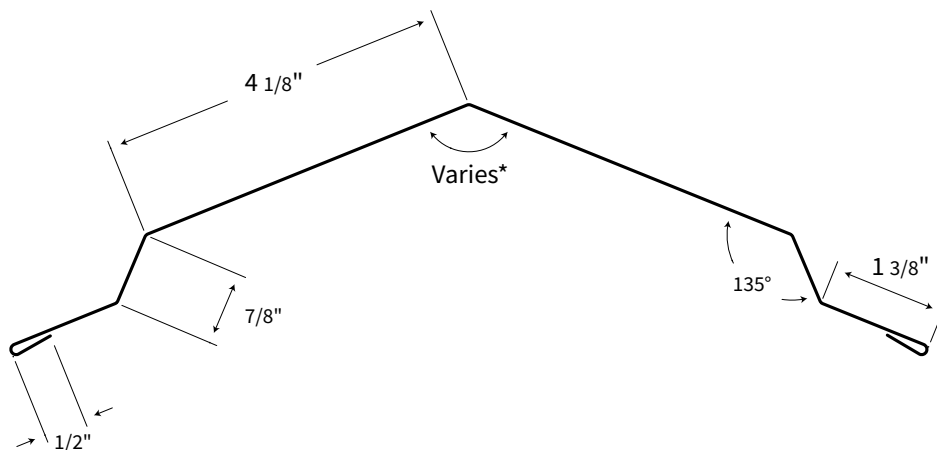

* See page 29 for angle specification

RIDGE CAP RC-3

(10' LENGTHS)

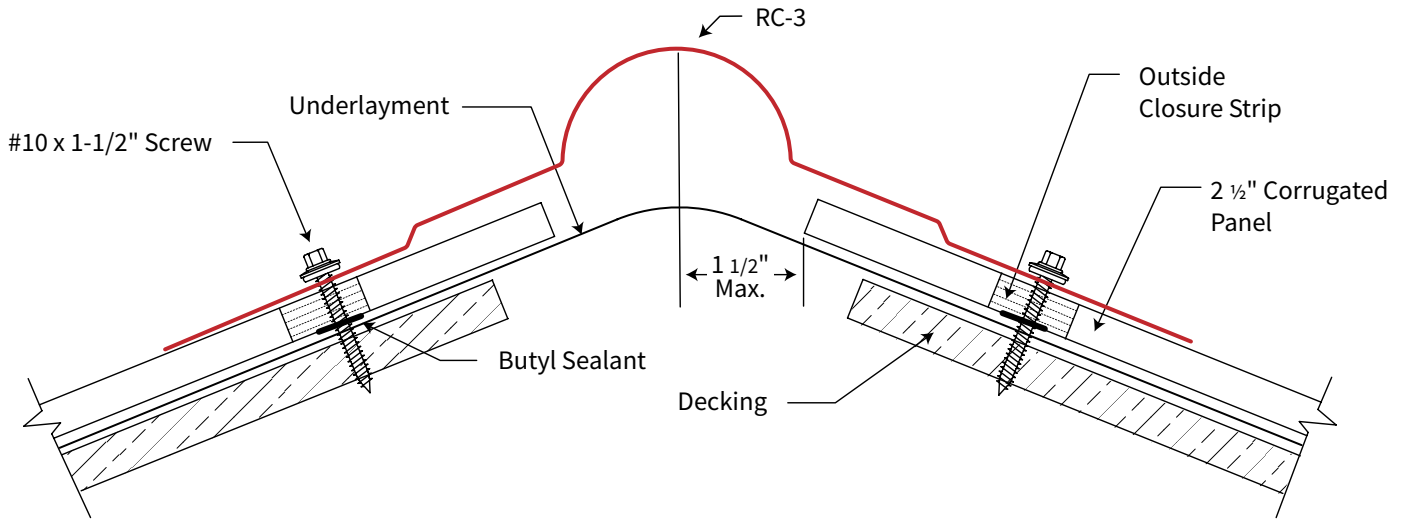

COMPONENT DETAILS

RC-3

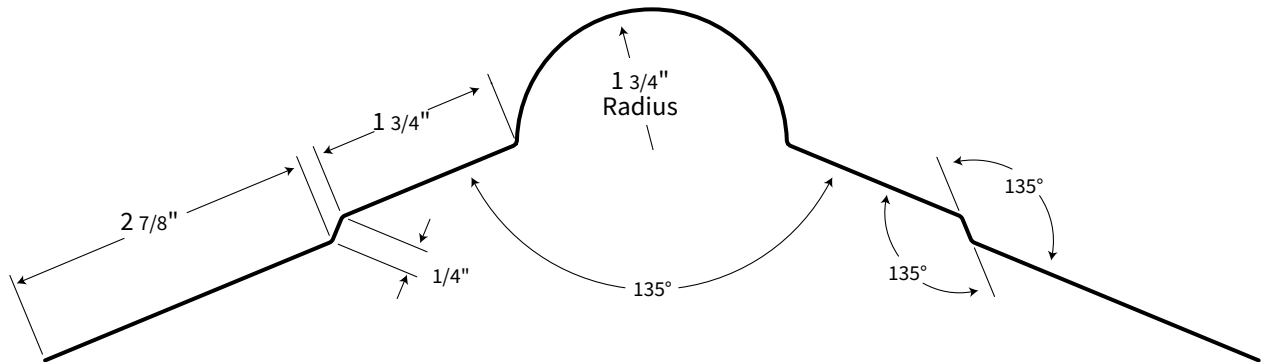

RIDGE CAP RC-8

(10' LENGTHS)

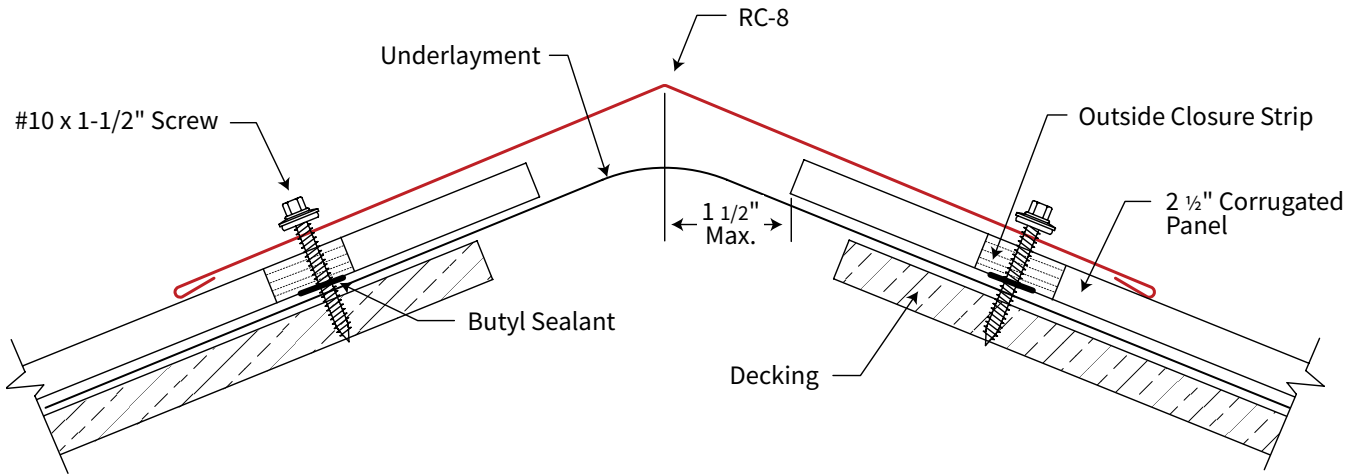

COMPONENT DETAILS

RC-8*

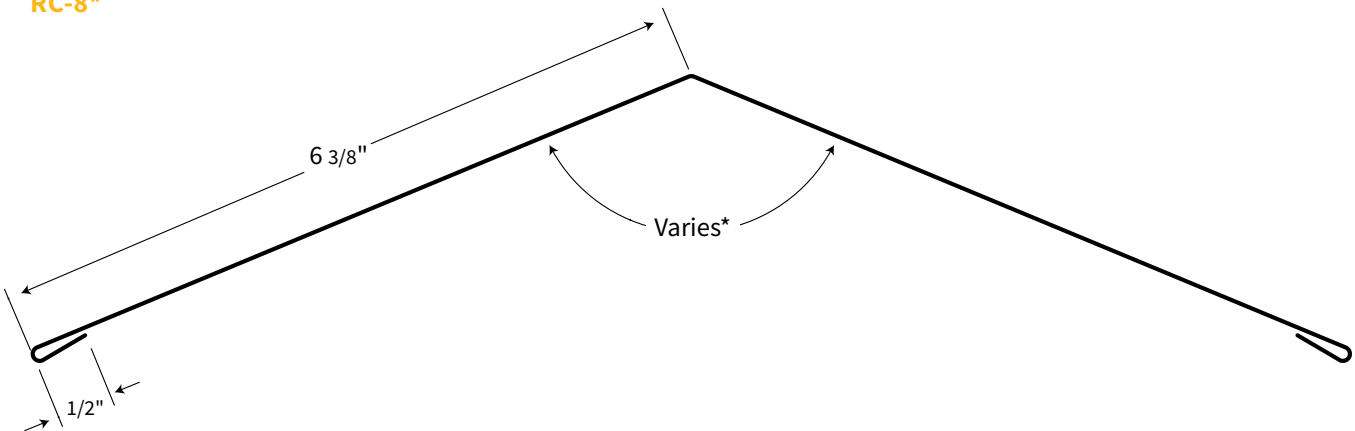

* See page 29 for angle specification

VENTED RIDGE WITH MIAMI-DADE APPROVED VENTED CLOSURE

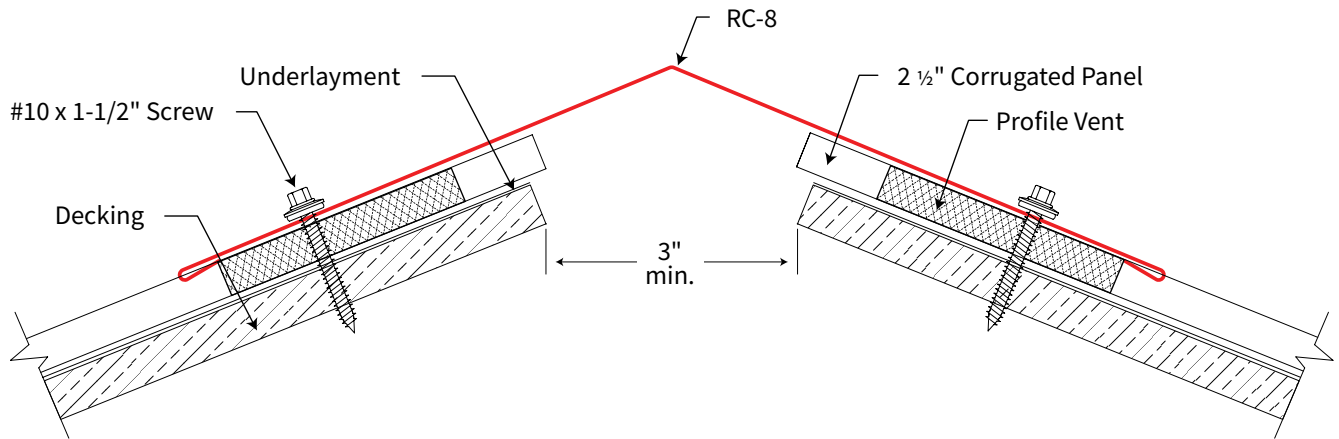

COMPONENT DETAILS

RC-8*

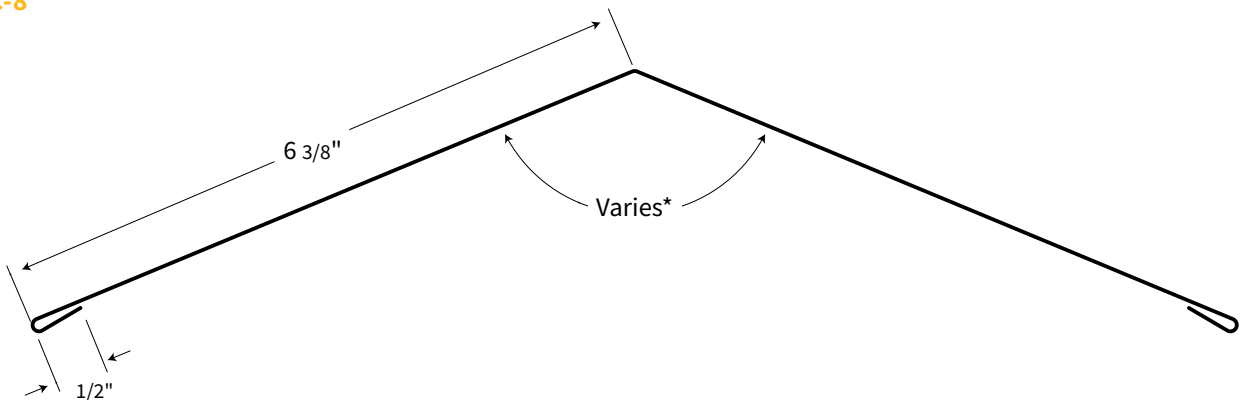

* See page 29 for angle specification

PIPE BOOT

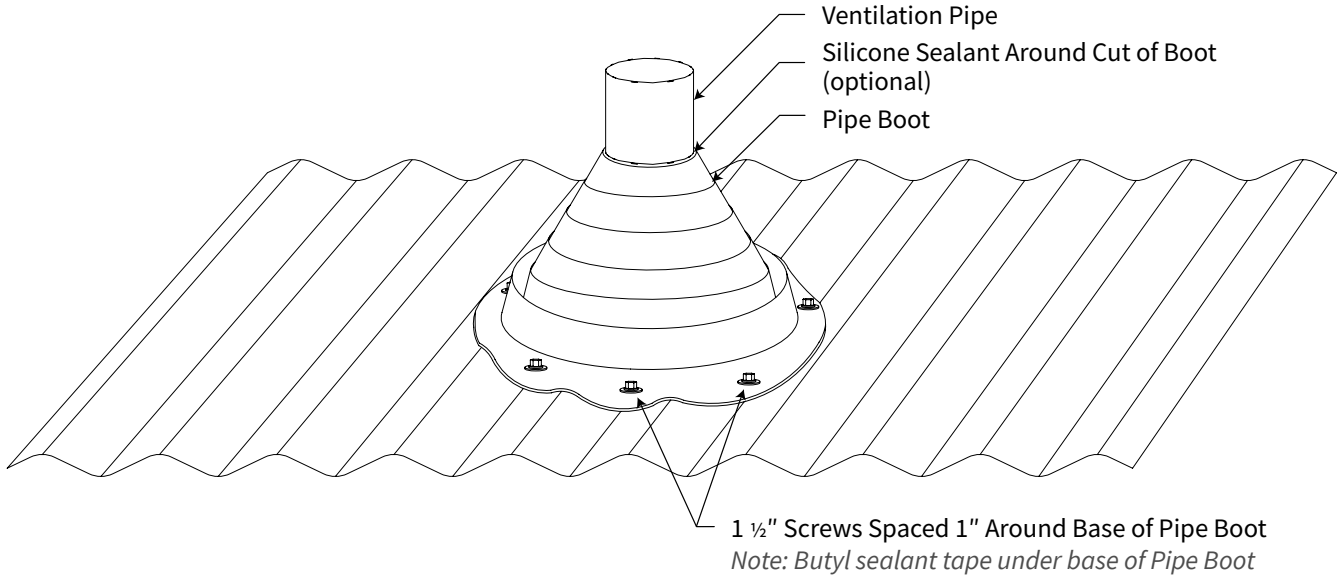

COMPONENT DETAILS

Standard Pipe Boot

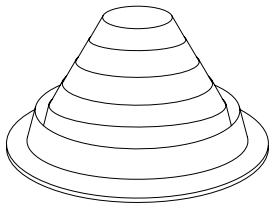

Zipper Pipe Boot

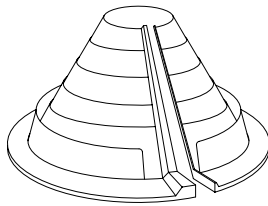

Flashing Pipe Boot

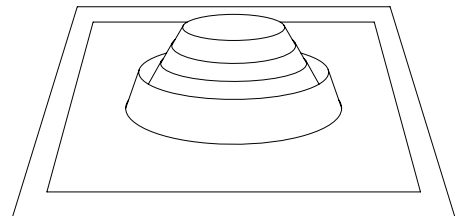

* See page 29 for angle specification

FASTENER GUIDE

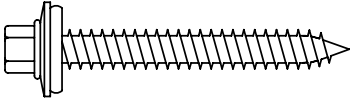
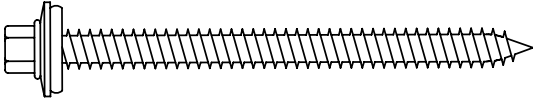
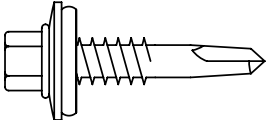
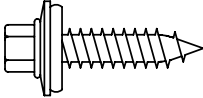
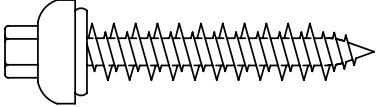
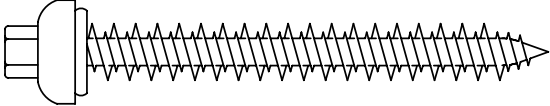
Fastener	Size	Panel Finish	Application
WOODSCREW 	#10 - 1 ½”		Fastening panels or trims to a wood substrate
WOODSCREW 	#10 - 2 ½”		Fastening panels or trims to a wood substrate
METAL SCREW 	#12 14 x 1”		Fastening panels or trims to a metal substrate
STITCH SCREW 	#12 - ¾”		Fastening trim to panels or other metal flashing
PREMIUM, LONG LIFE ZINC CAPPED WOODSCREW 	#10 - 1 ½”		Fastening panels or trims to a wood substrate
PREMIUM, LONG LIFE ZINC CAPPED WOODSCREW 	#10 - 2 ½”		Fastening panels or trims to a wood substrate
		Bare Galvanized	
		Painted	
		Bare Galvalume	
		Painted	

| SEALANT AND ACCESSORIES

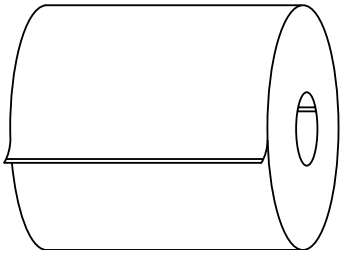

HIP SEALANT TAPE

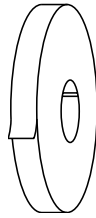

BUTYL SEALANT TAPE



TUBE SEALANT

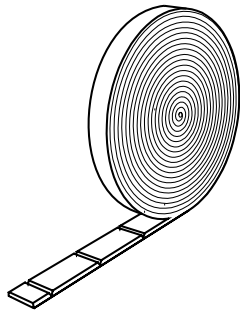

PROFILE VENT

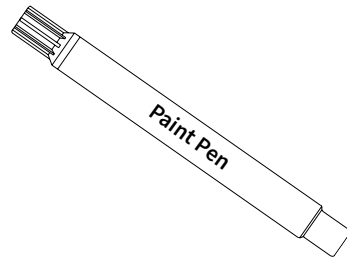

TOUCH UP PAINT

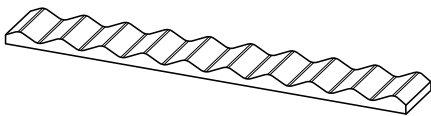

CLOSURE STRIP

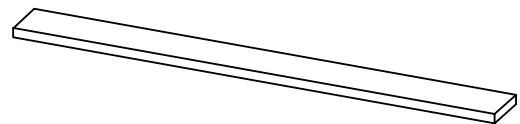

**UNIVERSAL
CLOSURE STRIP**

HELPFUL FORMULAS

Rise and Run	Multiply Flat Area by	LF of Hips or Valleys per LF of Common Run	Decimal Fraction of a Foot	
			Inch	Fraction
2 in 12	1.041	1.424	1"	.083
3 in 12	1.031	1.436	2"	.167
4 in 12	1.054	1.453	3"	.250
5 in 12	1.083	1.474	4"	.333
6 in 12	1.118	1.500	5"	.417
7 in 12	1.158	1.530	6"	.500
8 in 12	1.202	1.564	7"	.583
9 in 12	1.250	1.600	8"	.667
10 in 12	1.302	1.641	9"	.750
11 in 12	1.357	1.685	10"	.833
12 in 12	1.413	1.732	11"	.917
			12"	1.00

Roof Calculator

Height = 1/2 Span x Rise/Run
(common run)

Height = Span x Pitch

Slope = Common Run x Factor

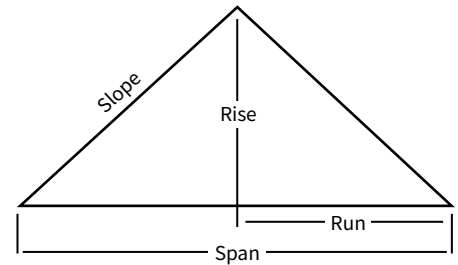

ROOF SLOPE CONVERSION TABLE WITH ROOF PITCH MULTIPLIER

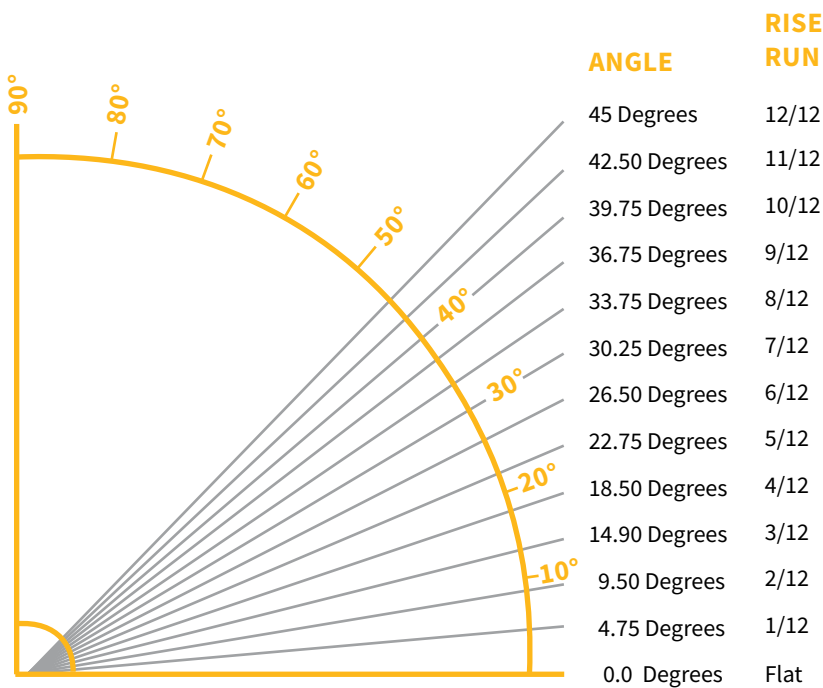

Triangle

Area = 1/2 x B x H



A = $\sqrt{C^2 - B^2}$ = H

B = $\sqrt{C^2 - A^2}$ = Run

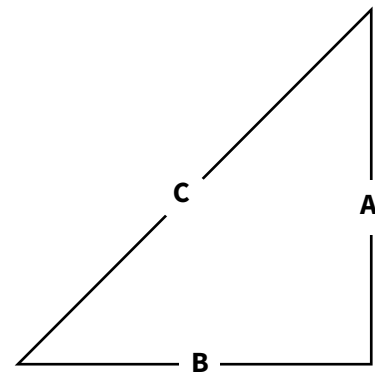
C = $\sqrt{A^2 + B^2}$ = Slope

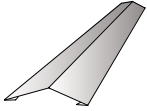
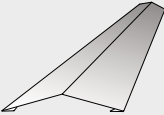
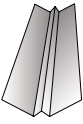
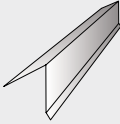
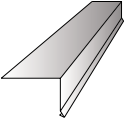
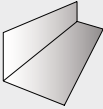
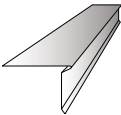
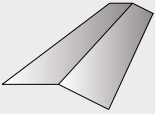
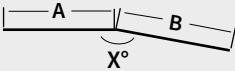
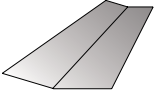

FLASHING ANGLE SPECIFIER CHART

Profile/Flashing	*	1:12	2:12	3:12	4:12	5:12	6:12	7:12	8:12	9:12	10:12	11:12	12:12
Ridge Cap 	135°	172°	162°	152°	144°	136°	128°	120°	114°	108°	104°	98°	90°
Hip Cap 	148°	172°	162°	152°	144°	136°	128°	120°	114°	108°	104°	98°	90°
Preformed Valley 	136°	173°	166°	160°	154°	148°	143°	138°	133°	129°	126°	122°	120°
High Side Eave 	67°	87°	81°	76°	71°	67°	63°	60°	56°	53°	50°	47°	45°
Eave Flashing 	90°	94°	99°	104°	108°	112°	116°	120°	123°	126°	128°	132°	135°
End Wall Flashing 	112°	94°	99°	104°	108°	112°	116°	120°	123°	126°	128°	132°	135°
Eave Drip 	90°	94°	99°	104°	108°	112°	116°	120°	123°	126°	128°	132°	135°
Gambrel Flashing 		94°	99°	104°	108°	112°	116°	120°	123°	126°	128°	132°	135°
		To calculate the required pitch (X°), use the following equation: $B^\circ - A^\circ = X, 180^\circ - X = \text{Angle}$											
Transition Flashing 		94°	99°	104°	108°	112°	116°	120°	123°	126°	128°	132°	135°
		To calculate the required pitch (X°), use the following equation: $A^\circ - B^\circ = X, 180^\circ - X = \text{Angle}$											

* Default Pitch unless otherwise specified

I NOTES

I NOTES

GIBRALTAR

BUILDING ACCESSORIES DIVISION